

PROTECT YOUR TRUCK. IT'S YOUR BUSINESS.

Truck equipment will fail. You just don't know WHEN, WHERE, WHAT or HOW MUCH it will cost. Let NTP take care of costly repairs and keep you moving and making money.

North America's #1 Most-Trusted Equipment Protection Provider

Major Equipment Repairs Are Expensive

CLAIMS PAID EXAMPLE (Engine)

\$9,500 / \$26,500

Average Claim Paid For All Repairs On That Component / Average Claim Paid For Top 20 Repairs On That Component

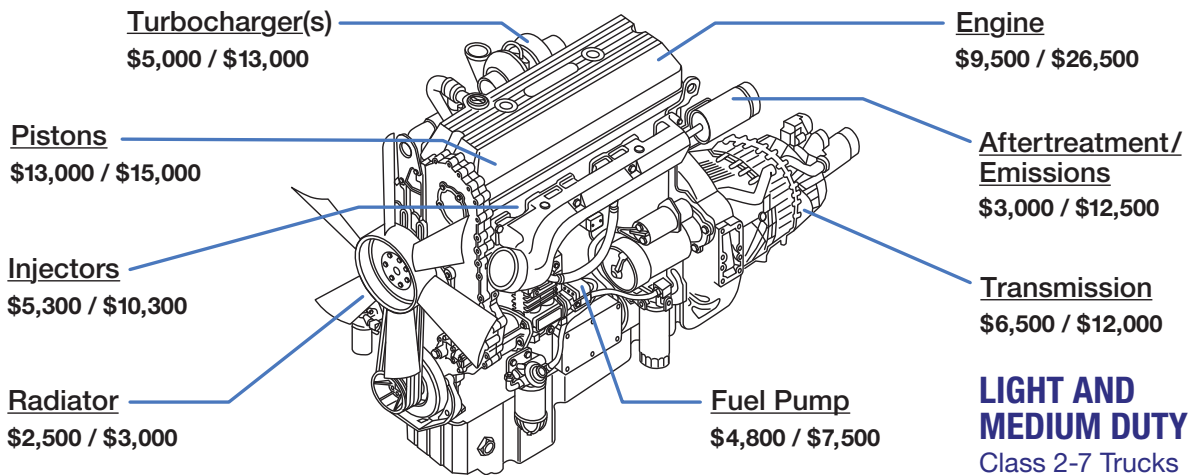

LIGHT AND MEDIUM DUTY
Class 2-7 Trucks

Source: Data is all claims paid by NTP Co. in 2023. A component repair cost will vary based on the repair needed.

© 2024 NTP Co., Inc.

High Risk of Equipment Failure After Factory Warranty Ends

Example of Basic Warranty Coverage for New LD/MD Trucks

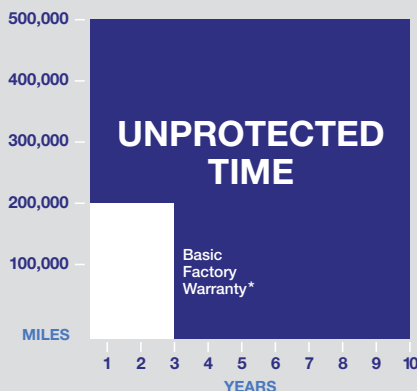

* Basic factory warranties vary and usually include engine and sometimes transmission.

Claims Paid Over Full Contract Term

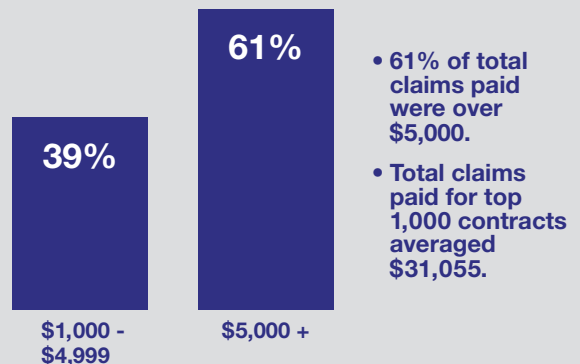

Costs are actual total repairs paid by NTP Co., Inc. on contracts reaching full term 2019-2023. © 2024 NTP Co., Inc.

NTP PREFERRED MD Truck Protection Plan

Medium Duty Class 2-7

COMMERCIAL USE ONLY

CLASS 5-7, up to 10 years including the current calendar year; start miles <300,000 miles; contract expires at 450,000 total miles. 16,001- 33,000 lb GVWR. Wrap coverage begins at expiration of prior OEM coverage (by age or mileage).

Covered Components Summary

\$350 deductible per occurrence

CC = Critical Components
LOL = Limits of Liability
VP = Value Pack™

Coverage Exclusions: Please refer to your vehicle service contract for complete list and details of covered and non-covered items.

Contract Owner: You must follow OEM maintenance guidelines to retain repair coverages.

Engine (LOL \$17,500) VP

- Camshaft and Cam Bearings
- Cam Followers
- Connecting Rods
- Connecting Rod Bearings
- Connecting Rod Caps and Screws
- Crankshaft
- Cylinder Block Casting
- Cylinder Head and Head Gasket
- Cylinder Liners
- Cylinder Head Bolts
- Hydraulic Lifters
- Injector Cups
- Intake and Exhaust Valves
- Intake and Exhaust Valve Guides
- Main Bearings
- Oil Cooler and Housing
- Oil Pan
- Oil Pump Pick Up Screen and Tube
- Oil Pump Pressure Relief Springs and Valves
- Pistons, Piston Rings and Piston Oil Cooling Jets
- Pushrods
- Rocker Arms and Rocker Arm Shafts
- Thrust Washers
- Timing Gears
- Timing Gear Cover and Housing
- Valve Cover
- Valve Retainers and Keepers (Locks)
- Valve Seats and Valve Springs
- Wrist Pins

"Non-oil" related components:

- Exhaust Manifold
- Flywheel Housing
- Intake Manifold
- Thermostat Housing
- Vibration Dampener

Progressive Damage, Wearout & Carbon Packing

Please refer to your contract for details on Progressive Damage, Wearout and Carbon Packing coverage.

(CC) Engine Fuel Injectors, Water Pump, Fuel Pump & ECM (LOL \$5,000) VP

- Complete Injector
- Fuel Injector Hard Lines
- Fuel Injection Pump
- Fuel Pump
- Engine Control Module (ECM)
- Water Pump

(CC) Turbo(s) (LOL \$7,500) VP

- Bearings
- Internal Variable Vane Assembly
- Turbine and Turbine Shaft
- Turbo Actuator

Transmission (LOL \$6,000) OPTIONAL

- | | |
|------------------------|--------------------|
| • Bands | • Oil Pump |
| • Bearings | • Shaft(s) |
| • Blockers | • Shift Forks |
| • Bushings | • Speed Sensor |
| • Control Module (TCM) | • Synchronizers |
| • Drums | • Thrust Washers |
| • Gear Sets | • Torque Converter |
| • Governor | • Valve Body |

Differential (LOL \$6,000) OPTIONAL

- | | |
|----------------------------|--------------------------------|
| • Axle Housing | Power divider includes: |
| • Axle Shafts | • Bearings |
| • Bearings | • Gears |
| • Bushings | • Shafts |
| • Carrier Case | • Shift Forks |
| • Gear Sets | |
| • Limited Slip Clutch Pack | |

Aftertreatment (LOL \$8,000) VP

- Aftertreatment Electronic Control Module (ACM)
- Back Pressure Control Valve (BPV)
- Diesel Exhaust Fluid (DEF) Module with Injection Nozzle
- DEF Heater Control Relay
- DEF Dosing Module - Wiring Harness
- DEF Heated Lines (3)
- DEF Heater Coolant Control Valve
- DEF Heating Elements
- DEF Heating Fittings (3 on Supply Module)
- DEF Pump and Module
- DEF Solution Level/Temperature Sensor
- DEF Tank
- Diesel Oxidation Catalyst (DOC)
- Diesel Particulate Filter (DPF)
- DPF Air, Fuel, and Coolant Lines
- DPF Air, Fuel, Manifold Assembly
- DPF Dosing Module
- Exhaust Gas Recirculation (EGR) Valves
- EGR Actuator
- EGR Connecting Bellows and Clamps
- EGR Cooler(s)
- Exhaust Piping, Clamps, and Gaskets
- Exhaust Throttle Valve
- Hydrocarbon Doser Injector (HC Doser, 7th Injector, ARD, AHI Module)
- Hydrocarbon Doser Valve - Air, Fuel, and Coolant Lines; and Inline Air Filter
- Hydrocarbon Doser Valve (Voss Valve)
- Selective Catalytic Reduction (SCR) Catalyst
- SCR Decomposition Pipe and Pipe Elbows
- Sensor, BPV Pressure
- Sensor, Delta P (DPF Pressure)
- Sensor, DOC Inlet Pressure
- Sensor, DOC (Post) Temperature
- Sensor, DOC (Pre) Temperature
- Sensor, DPF Air Supply Pressure
- Sensor, DPF Back Pressure
- Sensor, DPF Fuel Pressure
- Sensor, Lambda (O₂ Sensor)
- Sensor, NOx (2)
- Sensor, Pressure After Exhaust Throttle Valve
- Sensor, SCR (Post) Temperature
- Sensor, SCR (Pre) Temperature
- Wiring Harness - Emission Systems (including overlay)

Comfort Package® (LOL \$6,000) OPTIONAL

- Alternator
- Charge Air Cooler
- Engine Air Compressor
- Fan Clutch
- Fuel Tanks, Cap, & Valve
- HVAC Air Compressor & Pulley
- HVAC Blower Motor & Resistor
- HVAC Fan Hub
- HVAC Heater Core
- HVAC Temperature Controls, Control Head, & Control Valves
- Radiator & Radiator Cap
- Radio
- Starter & Starter Solenoid

Rapid Repair Guarantee Plus® OPTIONAL

This program guarantees that after the claim approval is complete, our National Repair Network will have you on the road within 14 days of all diagnostics being completed or we will pay you, or the lien holder, half of your monthly truck payment, up to \$750. If repairs require more than 30 days from the time the claim is approved, we will pay you, or the lien holder, your total monthly truck payment, up to \$1,500.

Roadside Assistance Provided By Roadside Masters OPTIONAL

- Fuel/Oil/Water/Fluid Delivery Service
- Jump Start
- Lock-out/Replacement Key
- Mobile Mechanic
- Pull Start
- Replacement Battery Delivery
- Tire Repair
- Tire Replacement
- Towing (50 miles)

Coverage begins 15 days after contract start date.

Underwriting

Dealer Requirements Before Sale

- Perform OEM recommended PM, and install new engine oil and filter.
- Check and repair/resolve all active and inactive fault codes.
- Visually inspect all covered components. Repair/resolve all deficiencies and leaks.
- Perform road test/performance evaluation. Identify and resolve all operating deficiencies for covered components.
- Check engine and aftertreatment performance and repair deficiencies (skips, knocking, exhaust smoke, clogged/dirty filter, etc.).
- Retain RO's for all repairs.

Auxiliary Power Unit (APU) (LOL \$4,000) OPTIONAL

- Internally lubricated hard parts limited to Camshaft and Cam Bearings
- Cam Followers
- Connecting Rods
- Connecting Rod Bearings
- Constant Velocity Valve
- Crankshaft
- Hydraulic Lifters
- Intake and Exhaust Valves and Guides
- Injectors
- Main Bearings
- Oil Pan
- Oil Pump Gears
- Oil Pump Housing
- Oil Pump Pick Up Screen
- Oil Pump Pick Up Tube
- Oil Pump Pressure Relief Springs and Valves
- Pistons, Piston Rings and Piston Oil Cooling Jets
- Push Rods
- Rocker Arm Shafts
- Rocker Arms
- Thrust Washers
- Timing Chain and Gears
- Timing Chain Tensioners
- Timing Gear Cover
- Valve Cover
- Valve Keepers (locks)
- Valve Retainers
- Valve Springs
- Wrist Pins
- Water Pump

No damage resulting from a seal leak or blown head gasket is covered.

Rental Truck Assistance OPTIONAL

This program provides reimbursement for a rental truck while your truck is being repaired for a covered claim. We offer 7-day and 14-day programs and your rental days can be used as needed during your contract term. Rentals must be arranged with an authorized rental truck facility. Maximum reimbursement rates are specified in your contract. Please contact an NTP Co. claims administrator prior to renting for other details. The driver renting the truck is responsible for showing proof of insurance, paying for fuel, mileage charges, and applicable vehicle damage that occurs during the rental period. They may also be asked for a security deposit and proof of having their CDL for 2+ years.