

PROTECT YOUR TRUCK. IT'S YOUR BUSINESS.

Truck equipment will fail. You just don't know WHEN, WHERE, WHAT or HOW MUCH it will cost. Let NTP take care of costly repairs and keep you moving and making money.

North America's #1 Most-Trusted Equipment Protection Provider

Major Equipment Repairs Are Expensive

CLAIMS PAID EXAMPLE (Engine)

\$9,500 / **\$26,500**
 Average Claim Paid For All Repairs On That Component / Average Claim Paid For Top 20 Repairs On That Component

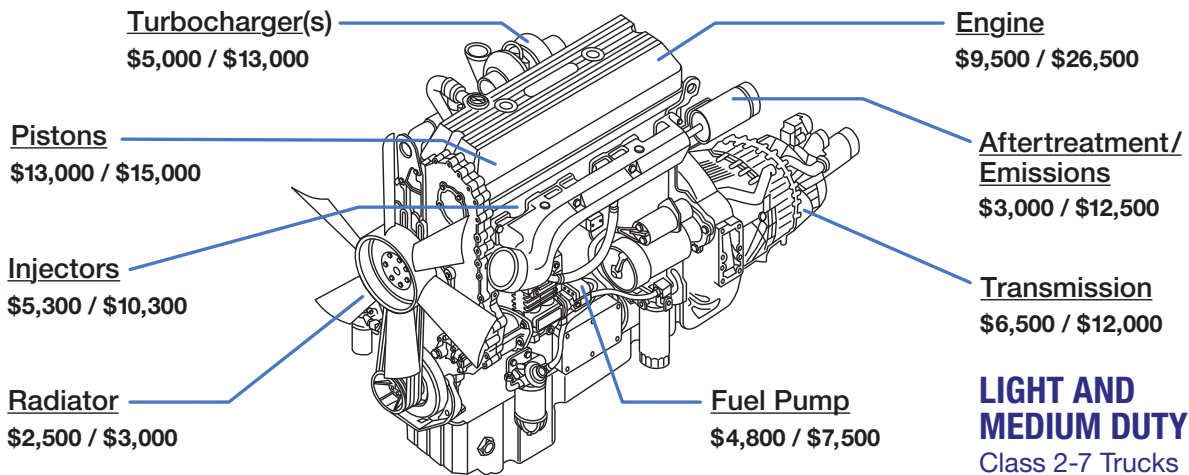

Source: Data is all claims paid by NTP Co. in 2023. A component repair cost will vary based on the repair needed.

© 2024 NTP Co., Inc.

High Risk of Equipment Failure After Factory Warranty Ends

Example of Basic Warranty Coverage for New LD/MD Trucks

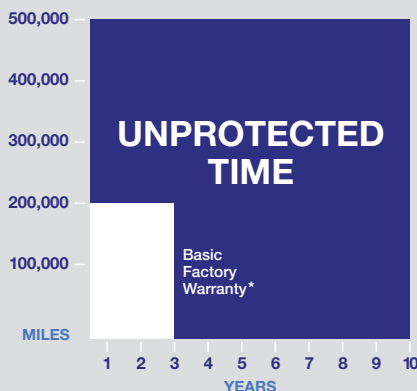

* Basic factory warranties vary and usually include engine and sometimes transmission.

Claims Paid Over Full Contract Term

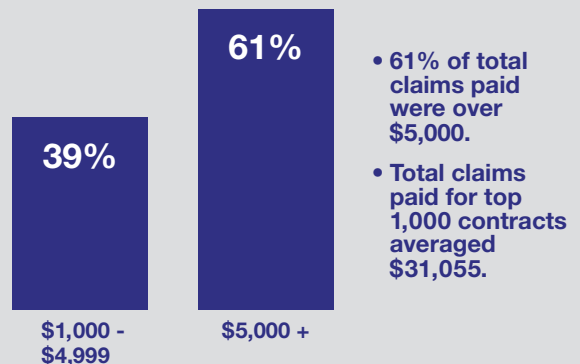

Costs are actual total repairs paid by NTP Co., Inc. on contracts reaching full term 2019-2023. © 2024 NTP Co., Inc.