

SLEEPER

HEAVY DUTY CLASS 8

Don't get caught paying for expensive repair bills!

Comprehensive Coverage on Engine, Transmission and Aftertreatment.

(See vehicle service contract for coverage and program details)

The Average Claim Expense:

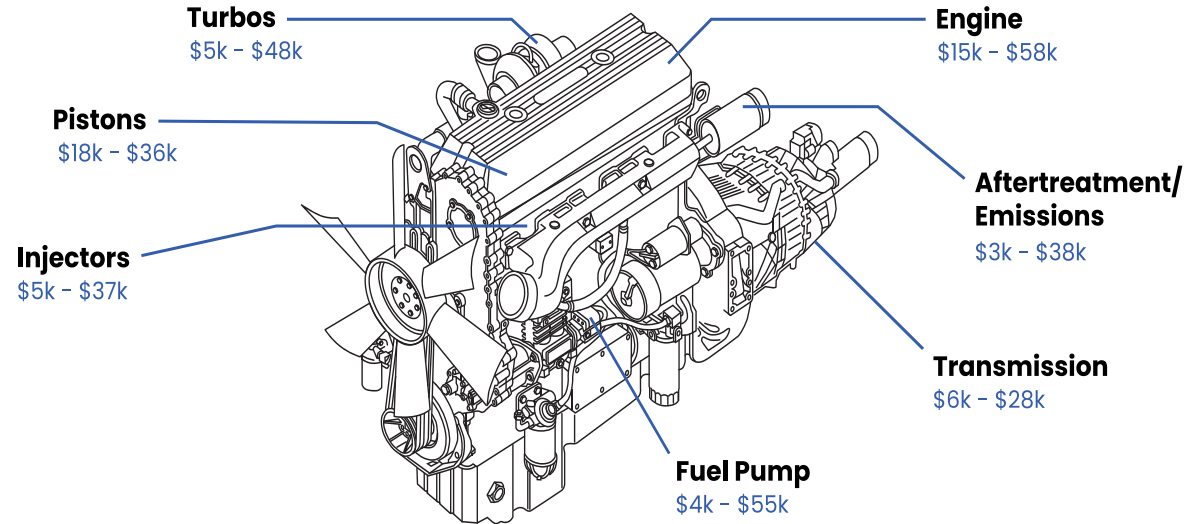

Protection That Keeps You Moving

- NTP's essential coverage pays for unplanned catastrophic failures, protecting your business and your livelihood.

Drive With Confidence

- As with accident and medical insurance you buy, having NTP coverage gives you peace of mind that you won't have to deplete your bank account to pay for expensive repairs.

You Can Trust NTP

- NTP has provided commercial vehicle protection since 1983.
- NTP has 6,000+ certified repair center partners in the US and Canada.
- Minimize your downtime with NTP. We manage all claims and pay repairs quickly.
- It's simple. If your failure is covered by the plan you purchased; we'll pay for the repair.





SLEEPER HEAVY DUTY CLASS 8

- Model age must be 8 years or newer from current calendar year
- Start miles <800K for 6, 12, 18, and 24 month plans; <700K miles for 36 month plans
- Contract expires at 1,000,000 total miles
- 2 tows reimbursed for covered claim, up to \$750 each
- Deductible: \$500 per occurrence

Engine

- Camshaft, cam bearings & cam followers
- Connecting rods, connecting rods bearings, caps and cap screws
- Crankshaft
- Cylinder heads, block casting, head bolts, head gasket & liner
- Exhaust manifold & flywheel housing
- Hydraulic lifters
- Intake manifold, intake and exhaust valve, valve guides & injector cups
- Main bearings
- Oil pan, oil cooler and housing
- Oil pump housing, gears, pickup screen & tube, pressure relief springs & pressure relief valves
- Pistons, piston rings & piston oil cooling jets
- Pushrods, rocker arms & shafts
- Thermostat housing
- Thrust washers
- Timing gears, cover and housing
- Valve cover, retainers, seats, springs & keepers (locks)
- Vibration dampener
- Wrist pins

Engine Fuel Injectors & More (Critical Components)

- Complete injector
- Fuel injector pump
- Fuel injector hard lines
- Fuel Pump & water pump
- Engine Control Module (ECM)

Turbo (Critical Components)

- Bearings
- Internal variable vane assembly
- Turbine and turbine shaft
- Turbo actuator
- Turbo boost sensor
- Vpad
- Turbocharger housing

Rapid Repair Guarantee Plus®

This program guarantees that once the claim approval is complete, our National Repair Network will have you on the road within 14 days, or we will pay you, or the lienholder, half of your monthly truck payment, up to \$750. If repairs require more than 30 days from the time the claim is approved, we will pay you, or the lienholder, your total monthly truck payment, up to \$1,500.

Transmission & Rear Differential

- Transmission:**
- Bands, Bearings
 - Blockers, Bushings
 - Control module (TCM)
 - Drums, Gear sets
 - Governor
 - Oil pump & shafts
 - Shift forks
 - Shift control housing
 - Speed sensor
 - Synchronizers
 - Thrust washers
 - Torque converter
 - Valve body
- Differential**
- Axle housing
 - Axle shafts
 - Bearings, Bushings
 - Carrier case
 - Gear sets
 - Limited slip clutch pack
- Power divider includes:**
- Bearings
 - Gears
 - Shafts
 - Shift forks

Rental Truck Assistance

Optional

Customer will be reimbursed for a rental truck from a vendor of their choice while their vehicle is being repaired. 7- or 14-day options.

Aftertreatment

- Aftertreatment electronic control module (ACM)
- Back pressure control valve (BPV)
- Diesel exhaust fluid (DEF) module
- DEF injection nozzle, heater control relay, dosing module - wiring harness, heated lines (3), heater coolant control valve, heating elements & fittings (3)
- DEF pump, module & tank
- DEF solution level/temp sensor
- Diesel oxidation catalyst (DOC)
- DOC doser injector
- Diesel particulate filter (DPF)
- DPF air, fuel, coolant lines, manifold assembly
- DPF dosing module
- Exhaust gas recirculation (EGR) valves
- Exhaust gas temperature sensor
- EGR actuator, coolers, connecting bellows & clamps
- Exhaust piping, clamps, gaskets and throttle valve
- Hydrocarbon doser injector (HC doser, 7th injector, ARD, AHI module)
- Hydrocarbon doser valve - air, fuel, coolant lines; and inline air filter and Voss valve
- Selective catalytic reduction (SCR) catalyst
- SCR decomposition pipe and pipe elbows
- Sensor, BPV pressure
- Sensor, delta P (DPF pressure/DPF soot/particulate level sensor)
- Sensors, DOC inlet pressure & DOC (post/pre) temp
- Sensor, DPF air supply pressure
- Sensors, DPF back pressure & DPF fuel pressure
- Sensor, lambda (O2 sensor)
- Sensor, NOX (2)
- Sensor, pressure after exhaust throttle valve
- Sensors, SCR (post/pre) temp
- Wiring harness - emission systems (incl. Overlay)

Comfort Package®

Optional

- Radiator & cap
- Alternator
- Charge air cooler
- Engine air compressor
- Fan clutch
- Fuel tanks, cap & valve
- HVAC air compressor
- Temp. Control & pulley
- HVAC blower motor & resistor
- HVAC control valves, fan hub, & heater core
- Starter & starter solenoid

Electronix Package™

Optional

- Adaptive braking and cruise control
- Anti-roll sensor & antenna
- Battery cable access
- Chassis ecms
- Collision avoidance
- Driver assistance system control units
- Lane assist & departure (camera & sensors)
- Light control module
- Navigation system head unit
- Power distribution module
- Power windows, doors & mirrors
- Primary driver gauge cluster
- Radio and single SAM
- Turn signal & wiper controls

APU (Auxiliary Power Unit)

Optional

- Camshaft and cam bearings
- Cam followers
- Connecting rods
- Connecting rod bearings
- Constant velocity valve
- Crankshaft
- Hydraulic lifters
- Intake and exhaust valves and guides
- Injectors
- Main bearings
- Oil pan
- Oil pump gears
- Oil pump housing
- Oil pump pick-up screen
- Oil pump pick-up tube
- Oil pump pressure relief springs and valves
- Pistons
- Piston rings
- Piston oil cooling jets
- Push rods
- Rocker arm shafts
- Rocker arms
- Thrust washers
- Timing chain and gears
- Timing chain tensioners
- Timing gear cover
- Valve cover
- Valve keepers (locks)
- Valve retainers
- Valve springs
- Wrist pins
- Water pump

CLASS 8 PRICING	Engine, Aftertreatment, Trans & Rear Diff.	Engine, Trans & Rear Diff.
6 Months / 50K Miles	\$3,595	\$2,895
12 Months / 100K Miles	\$4,995	\$3,895
18 Months / 150K Miles	\$6,395	\$4,595
24 Months / 200K Miles	\$7,795	\$5,795
36 Months / 300K Miles	\$9,995	\$7,695

Mileage Surcharge for vehicles with >400,000 + \$895

Additional Coverages	6 Mo.	12 Mo.	18 Mo.	24 Mo.	36 Mo.
Electronix Package	N/A	\$699	\$799	\$899	\$1,099
Comfort Package	N/A	\$699	\$849	\$999	\$1,199
AUX. Power Unit	N/A	\$599 for 12 thru 36 Months			
Rapid Repair Plus	Included in all programs				
Rental Truck Program	7 Days - \$159		14 Days - \$319		

Generous Coverage with High Limits of Liability	Limits of Liability
Engine	\$25,000
Fuel Injectors, Water Pump, Fuel Pump, and ECM	\$6,000
Turbocharger	\$7,500
Transmission / Rear Differential	\$7,500 / \$7,500
Aftertreatment	\$8,000
Comfort package®	\$6,000
Electronix package™	\$6,000
APU	\$4,000
Labor Rate Cap	\$175/Hour
AGGREGATE: Lesser of ACV or \$40,000	

877-950-3200

claims@ntpc.com

ntpwarranty.com

* Whichever is greater. Some variances on mileage and age restrictions may apply. Underwriting: NTP inspection process required. Repair costs based on NTP claims data. See contract for complete coverage and conditions © 2025 National Truck Protection Co., Inc.

© National Truck Protection Co., Inc. NTP_Penske_PMktgBrochure_Class8_V1 040726